

Repairing / Sealing

Drainage Holes

to engineered standards

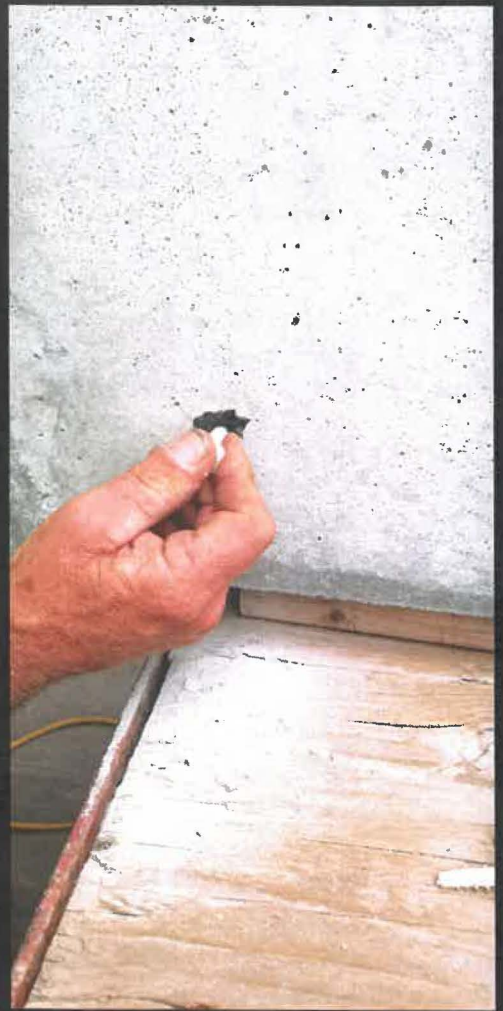
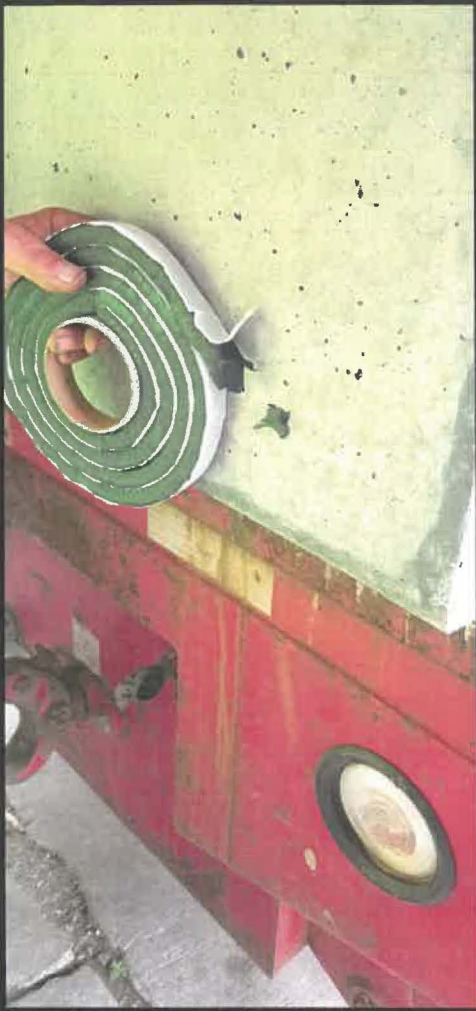

SSTS application for sewage tank listing

Subsurface Sewage Treatment Systems (SSTS) Program

Doc Type: Permit Application

General requirements for submittal

All submitted material (written responses and other materials) must be legible, typed, or printed. Handwritten responses to the application questions or handwritten notes or other submitted documentation may, at the discretion of the department, result in rejection of the application.

Please submit to: Corey Hower
 Minnesota Pollution Control Agency
 7381 Airport View Dr SW
 Rochester, MN 55902

MPCA Use Only	
Review complete:	Date
Choose:	Date
<input type="checkbox"/> Tank listed:	Date
<input type="checkbox"/> Comment sent:	Date

Applicant information

Manufacturer's name: Del Zotto Products of Minnsota Inc. Date of application: 10/19/2021
 Address: 1900 Co Rd 1
 City: Wrenshall State: MN Zip code: 55797
 Contact name: Troy Del Zotto
 Contact address:
 (if different from Manufacturer's)
 Address: _____
 City: _____ State: _____ Zip code: _____
 Telephone number: 218-384-3066 Fax number: 218-384-3087
 Email address: T.delzotto@delzottolink.com Website (homepage): www.delzottoprecastforms.com

Listing requirements

Manufacturers desiring to sell a sewage tank for use in Minnesota may request and obtain department review of requirements outlined in Minn. R. chs. 7080.1900 through 7080.2010, and thus be included on a list available to the general public.

Additional submittal requirements

- Related technical information, including schematics, characteristics; baffle dimensions, dimensioned drawings, and photos, etc.
- Siting and installation requirements, specifically including maximum recommended burial depth.
- Maintenance requirements, including recommended service schedule for all components.
- A signed and dated certification from a licensed professional engineer that the structural integrity of the tank (specify model(s)) is verified to determine the horizontal and vertical loads that the tank can withstand when empty, as stated in Minn. R. ch. 7080.2010. Included in the submittal should be strength calculations, testing results, etc. This should include the statement, "I certify that I represent (*Manufacturer's Name*), and that I am authorized to certify structural integrity for the tank(s) presented in this application. I attest, under penalty of law, that information is true, accurate, and complete."
- Certification by an agent of the manufacturer that adequate watertight testing has been completed per the requirements in Minn. R. ch. 7080.2010. Copies of relative testing results should be submitted. These also shall be maintained by the manufacturer for three years and must be available to the commissioner and local units of government if requested.
- Certification that each tank model meets all requirements of Minn. R. chs. 7080.1900 – 7080.2020 (see checklist for each model).

Annual submittal requirements

At least one sewage tank per year, per model, must be tested for watertightness, as stated in Minn. R. ch. 7080.2010. Manufacturers desiring to continue tank listing must submit appropriate watertight testing data by December 31, each year to remain on the list.

For more information

For more information or additional copies contact Corey Hower of the Minnesota Pollution Control Agency at the address above or by calling 507-206-2603 or 1-800-657-3864.

Tank information (complete one for each tank model submitted)

Model: DZ-2500- -WZ

Tank description

Liquid capacity: 2622 Gallons per compartment

Tank material:

- Concrete
 Fiberglass-reinforced polyester
 Polyethylene
 Other: _____

Tank use: (check all that apply)

Single compartment	Multiple compartments	
<input checked="" type="checkbox"/> Septic	<input checked="" type="checkbox"/> Septic/Septic	<input checked="" type="checkbox"/> Septic/Pump
<input checked="" type="checkbox"/> Pump	<input checked="" type="checkbox"/> Pump/Pump	<input checked="" type="checkbox"/> Septic/Holding
<input checked="" type="checkbox"/> Holding	<input checked="" type="checkbox"/> Holding/Holding	<input checked="" type="checkbox"/> Privy/Privy
<input checked="" type="checkbox"/> Privy	<input type="checkbox"/> Other: _____	

Maximum burial depth: 7ft

Certification

I certify that all other Minn. R. ch. 7080 requirements are met, including:

- Allowable liquid depth (Minn. R. ch 7080.1920 subp, A)
 Minimum of six feet between inlet and outlet (Minn. R. ch 7080.1920 subp, B)
 Inlet at least two inches higher than outlet (Minn. R. ch 7080.1920 subp, D)
Baffle height above liquid surface must meet one of the following: (Minn. R. ch 7080.1920 subp, E)
 Not less than 6 inches or 100 gallons, whichever is greater, for all liquid depths with an effluent screen and alarm or for liquid depths less than 39 inches without an effluent screen and alarm.
 At least eight inches for liquid depths of 39 inches or more without an effluent screen and alarm.
 Compartmented tanks (Minn. R. ch. 7080.1950):
- If septic tanks are compartmentalized, the first compartment must be equal to or larger than the rest of the tanks
- Has adequate venting
- Compartment walls can withstand weight of effluent against an empty compartment
 Baffles do or can (when installed) meet the sizing and placement of (Minn. R. ch. 7080.1960 D., E., F., and G.)
 Access requirements (Minn. R. ch. 7080.1970)
 Construction requirements (Minn. R. ch. 7080.1980)
 Have a method to lift tank for an ultimate load that is four times the working load (Minn. R. ch. 7080.1990 subp. 1, A)
 Tanks will undergo proper curing (verified by concrete test results) (Minn. R. ch. 7080.1990 subp. 1, B)
 No penetration points or openings in the exterior walls or tank bottom below the tank liquid level (bottom of outlet). (Minn. R. ch 7080.1990, subp 1, C).
 Sewage tanks will be clearly marked (Minn. R. ch. 7080.2020)

I certify that adequate watertight testing has been completed per the requirements in Minn. R. ch. 7080.2010.

I certify that structural integrity of the tank has been verified in accordance with Minn. R. ch. 7080.2010.
(Also include Registered Engineer's certification if completed.)

Print name: Troy Del Zotto

Title: Management

Signature: _____

Date: _____

(Please conserve paper by printing double-sided copies.)

Del Zotto Products of Minnesota, Inc.

VACUUM TEST REPORT

Test date: 10/11/2021

Model DZ-2500- ** -WZ

Note: The DZ-2500 MOLD is used to make all the 2500-gallon tank variants

- DZ-2500-H_____ Holding Tank
- DZ-2500-P_____ Pump Housing
- DZ-2500-S_____ Septic Single Compartment
- DZ-2500-C-S/P_____ Septic Dual Compartment (Septic tank / Pump housing)
- DZ-2500-C-S/S_____ Septic Dual Compartment (Septic tank / Septic tank)

DZ-2500-_____ - WZ The "WZ" or "Winterization" added to end of the tank's model number indicates that the tank has additional drainage holes for that model.

Tank Description: A 2500-gallon tank with two 24" Manhole openings in the cover. The Tank has one Inlet opening and one outlet opening on opposing sidewalls. The tank has two ¼ inch drainage holes located 4.5 inches up and 4.5 inches in from that bottom and side. These are sealed with Mastic DZ-102B and a chemically resistant PPSD (Premiant Positive Seal Device). The tank has a top seam, and cover slab interlocking with the walls. Join sealant applied in the seams is Mastic DZ-102B.

Structural test:

Interstate Pneumatics G2024-030V 2-1/2 Inch 30 PSI - 1/4 Inch NPT HG Vacuum Pressure Gauge.

Maximum pressure tested: 4.0+ Hg.

Vacuum was held at 2.8 0 Hg for 1 hour (12 times longer than the required 5 minutes) with no loss of air in the tank. Tank was inspected there were no Signs of cracking.

Witnessed By: Troy Del Zotto

Signed _____ Date: _____

Tests by: Dan Chapinski

Signed _____ Date: _____

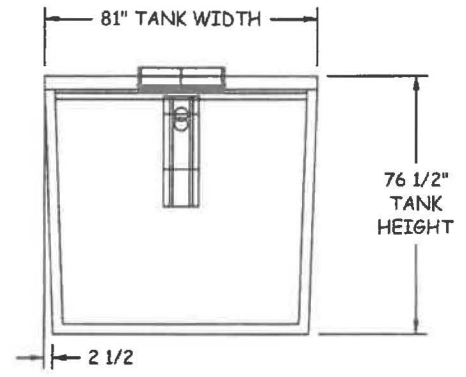
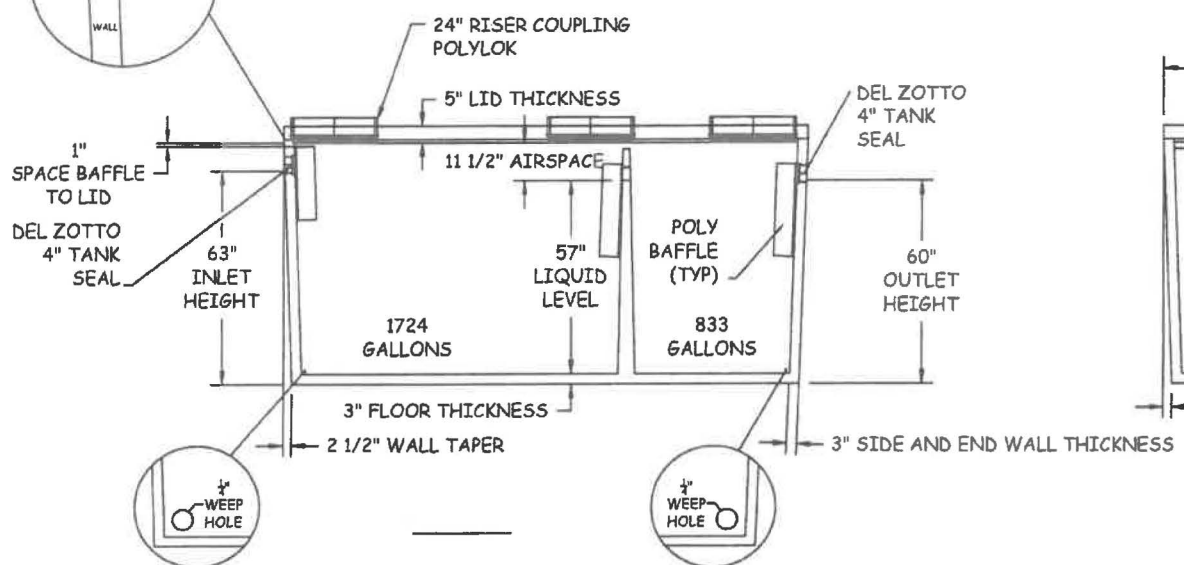
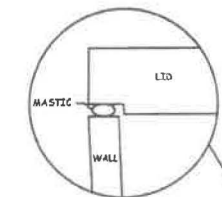
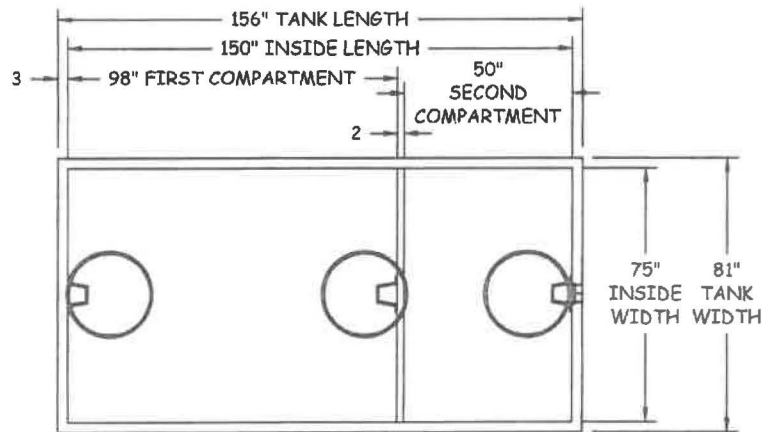

SHOWN AS A DZ-2500 C -S/S -S/P

Del Zotto Products of Minnesota
 1800 County Road #1, Wrentham, MN 55797 218-384-3088 Fax 218-384-3088

DRAWING DESCRIPTION: DZ-2500 C -S/S -S/P
 Septic Tank

This drawing and the information contained herein is the exclusive property of Del Zotto of Minnesota, Inc. and shall not be reproduced, used or disclosed to others except as authorized through written consent from Del Zotto of Minnesota, Inc.

UNLESS OTHERWISE SPECIFIED:
 DIMENSIONS ARE IN INCHES
 TOLERANCE ON DIMENSIONS:
 FRACTIONS/16
 DECIMALS/32
 REMOVE ALL BURRS AND BREAK ALL SHARP EDGES

DATE A	DRAWN BY DLS	REV E
FILE NAME Q2DZ2500CSSPCADD	SCALE 1:48	DATE 08/27/21
		SHEET 1 OF 1



Rochester Office | 7381 Airport View Drive SW | Rochester, MN 55902 | 507-285-7343

800-657-3864 | Use your preferred relay service | info.pca@state.mn.us | Equal Opportunity Employer

November 9, 2021

Jack Perry
Taft/
2200 IDS Center, 80 South 8th Street
Minneapolis, MN 55402

RE: Tank Registration Process - Notice of Sewage Tank Listing – Denial Notice
Description: Sewage, Holding, and Pump Tanks, Concrete
Manufacturer: Del Zotto Products, Inc.
Product File Number: 2013-002
Model Numbers: DZ-2500-WZ, DZ-2500-S-WZ, DZ-2500-C-S/P-WZ, DZ-2500-C-S/S

Dear Jack Perry:

Thank you for submitting the sewage tank application for Del Zotto Products, Inc. (Regulated Party) that includes the following sewage tank model: DZ-2500-WZ, DZ-2500-S-WZ, DZ-2500-C-S/P-WZ, DZ-2500-C-S/S.

In accordance with Minn. R. ch. 7080, the Minnesota Pollution Control Agency (MPCA) has reviewed the Regulated Party's submitted materials, requesting the approval for the listed sewage tanks. Based on the submitted documentation, the MPCA finds that the sewage tanks are not in compliance with Minn. R. 7080.1990 Subpart 1, C.

Sewage tanks cannot have holes below the operating depth in order to be registered with the State of Minnesota.

If you have any questions, please contact me at 507-206-2603 or e-mail corey.hower@state.mn.us.

Sincerely,

A handwritten signature in black ink that reads 'Corey J. Hower'.

Corey J. Hower
Engineering Specialist
Municipal Division

cc: William Del Zotto
Troy Del Zotto
Michelle Janson, Attorney, MPCA
Steven Oscarson, MPCA
Aaron Jensen, MPCA



ARROWHEAD PRODUCT DEVELOPMENT, INC.

4940 Lightning Dr., Ste. 5, Hermantown, MN 55811 gwerkhoven@arprodev.com
218-525-5210 Office 218-525-1909 Fax www.arprodev.com

Project: Test Viability of plugs in septic tank



Customer:

Del Zotto Products of MN
1900 County Road 1

By Greg Werkhoven

Date 9/3/21

I certify that this plan, specification or design was prepared by me or under my direct supervision and that I am a registered Professional Engineer under the Laws of the State of Minnesota.

Greg Werkhoven

Date 9/3/21 Registration No. 24862

Larson Engineering, Inc.
 3524 Labore Road
 White Bear Lake, MN 55110-5126
 651.481.9120 Fax: 651.481.9201
 www.larsonengr.com

SUBJECT: Septic Tank Certification
 Del Zotto Products of MN

SHEET NO. 15
 PROJECT NO. 11-12-0267
 BY SRN DATE 03/20/2012



Larson

2500 Gallon 2 Compartment Septic Tank (DZ-2500 2cmp)

Length = 13 FT Concrete Density = 145 PCF
 Width = 6.75 FT Soil Density = 130 PCF
 Depth = 6.38 FT Lateral Soil Pressure = 70 PCF
 Net Lid Area Covered with Soil = 80.8 FT²

Test pressures and added weight on lid required to simulate designated burial depth

Burial Depth to Lid, ft	Soil Weight Above Lid, lb	Top - Soil Lateral Pressure, psf	Bottom - Soil Lateral Pressure, psf	Average Soil Lateral Pressure, psf	Test Pressure, inHg	Additional Weight on Lid, psf	Additional Weight on Lid, lb
1	130	70	516	293	4.2	0	0
2	260	140	586	363	5.2	0	0
3	390	210	656	433	6.1	0	0
4	520	280	726	503	7.1	17	1,363
5	650	350	796	573	8.1	77	6,209
6	780	420	866	643	9.1	137	11,055
7	910	490	936	713	10.1	197	15,902
8	1,040	560	1,006	783	11.1	257	20,748
9	1,170	630	1,076	853	12.1	317	25,594
10	1,300	700	1,146	923	13.1	377	30,440

I hereby certify that this plan, specification, or report was prepared by me or under my direct supervision and that I am a duly Licensed Professional Engineer under the laws of the State of Minnesota.

Print Name Sean R. Noren

Signature: Sean R. Noren

Date: 3/20/12 License #44634



This picture shows the mastic on the plug to provide additional sealing in addition to the plug. It should be noted that the covers of all the tanks set in place via gravity with only a mastic seal and it functions well in the field.

We numbered the holes on each side of the wall sections and closely monitored the forces to push out the plugs. Note the slight spalling of the inside surface, but the end of the plug is recessed in the hole by at least 1" beyond any damage. (See below)



Arrowhead Product Development, Inc. was retained by Mr. William Del Zotto of Del Zotto Products of MN to test the security of a plug that had been placed in a small number of his septic tank products. The holes had been drilled into the tanks that were stored outside to drain rainwater when it rained. It is my understanding that only the large tanks needed this as they cannot be hauled with the cover in place as they are too large for the trucks, so they are stored without their covers installed to prevent damage by repeated installations of the covers. This report speaks to the adequacy of the plastic plug as an effective stopper to prevent leaks. It does not endorse nor support the practice of putting the holes in the tank. This practice is beyond my prevue as a mechanical engineer, and I will only speak to the adequacy of the plug.

The holes are made with a hammer drill and a 1/4" masonry bit. I measured the holes by sliding a 1/4"Ø into the hole and they are very close to 1/4"Ø. A 5/32" Ø bit did not fit in any of the holes save for Hole #7 (the one that was slightly oversize), and it just started into that one.



The pieces that we used for the test were from the 3" thick walls of a scrap tank that is the same model wherein some of the drain holes were drilled. We drilled a sample set of 12 holes, installed the plugs with and without the aid of mastic sealer (mastic was installed in all of the tanks that were installed in the field). It should be noted that the plugs fit so tightly in the holes that a hammer is required to pound them in as they will not push in by hand. See the picture above.

Below is a picture of the load cell that was used to measure the dislodging force required to unseat the plug



We tested the accuracy of the load cell against the accuracy of a bench scale at very light pressures, as we did not want to dent the surface of the bench scale with the tiny probe so we kept the pressures light. The load cell would be more accurate if we took it up to somewhere mid-range, but our purpose was to insure it was working properly. The accuracy is displayed below. At this very light weight the accuracy is 9% which is very acceptable.

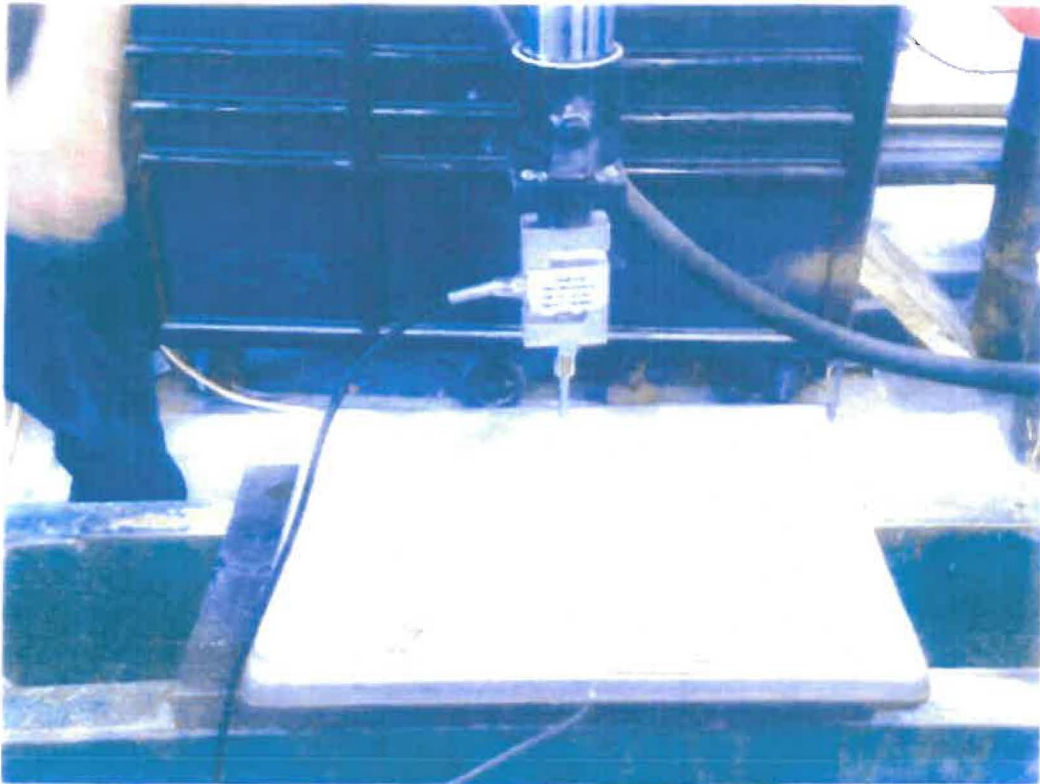

Attachment A: is the data gathered to push out the plugs. The average force to dislodge the plugs was 142 lbs. It would require an average pressure within the tank of 2,896 PSI to develop the required 142 lbs. to dislodge the plug. Each pressure required to develop the dislodging force is shown on attachment A. Once the plugs were dislodged and started moving, the force to keep the plug moving decreased to somewhere between 35 – 60 lbs. That equates to an internal tank pressure (sustained) of 714 – 1225 PSI.

Attachment B is a screen shot of the specific gravity of sewage. The highest value of this specific gravity is 1.4. Using these numbers against the most possible pressure head inside the tank (distance from bottom of baffle to bottom of tank) 57" (See exhibit C Tank print). The pressure in psi is about 15.1 PSI.

Based upon the numbers presented here, the factor of safety range from $\pm 192:1$ (average highest) to 47:1 at the average lowest. In short, the plug cannot see a pressure anywhere near what it will take to dislodge it. The septic tank itself would physically explode before enough pressure could be generated to dislodge the plug. Further, if the mastic sealer is good enough for the cover to prevent leakage, it will be good enough to prevent leakage through the tiny hole, even withstanding the driven in plastic plug which is designed to prevent leakage.

It is my professional opinion that the plugs are adequate to stop any leakage and will stay in place because no pressure can exist that will drive them out.

Test Data for dislodging Plugs from hole

Test No	Force to dislodge Plug~#	Equivalent Pressure in tank to create force~PSI	Comments
1	82	1670	Mastic on Plug - Workpiece No. 1
2	140	2852	No Mastic on Plug - Workpiece No. 1
3	85	1732	Mastic on Plug - Workpiece No. 1
4	90	1833	No Mastic on Plug - Workpiece No. 2
5	300	6112	No Mastic on Plug - Workpiece No. 2
6	120	2445	Mastic on Plug - Workpiece No. 2
7	19	387	Mastic on Plug - Workpiece No. 2 Hole hard to drill, slightly oversized
8	190	3871	Mastic on Plug - Workpiece No. 2
9	150	3056	Mastic on Plug - Workpiece No. 2
10	195	3973	Mastic on Plug - Workpiece No. 2
11	195	3973	Mastic on Plug - Workpiece No. 2
12	140	2852	Mastic on Plug - Workpiece No. 2
Average	142	2896	

Hole diameter = 1/4"

$$A = ((.25)^2 \times \pi) / 4 = 0.0491$$

Force = Pressure X Area

Pressure = Force/Area

General Observations:

1. The maximum pressure required to dislodge the plug and get it moving is what is shown
2. The noted pressure to keep all but #7 moving was between 35# - 60#
3. #7 Had a slight spike to dislodge (too quick to note) and then took 19# to push out.
4. The accuracy of the scale was checked against a scale at very low force - 11# -> 9% error - load cell okay

1/4" DIA. HOLE IN PLUG

specific gravity of sewage water



At

1.2

1.4

1.6

1.8

2.0

2.2

Generally, the specific gravity of municipal sewage lies **between 1.2 to 1.4** which is **slightly** greater than 1.

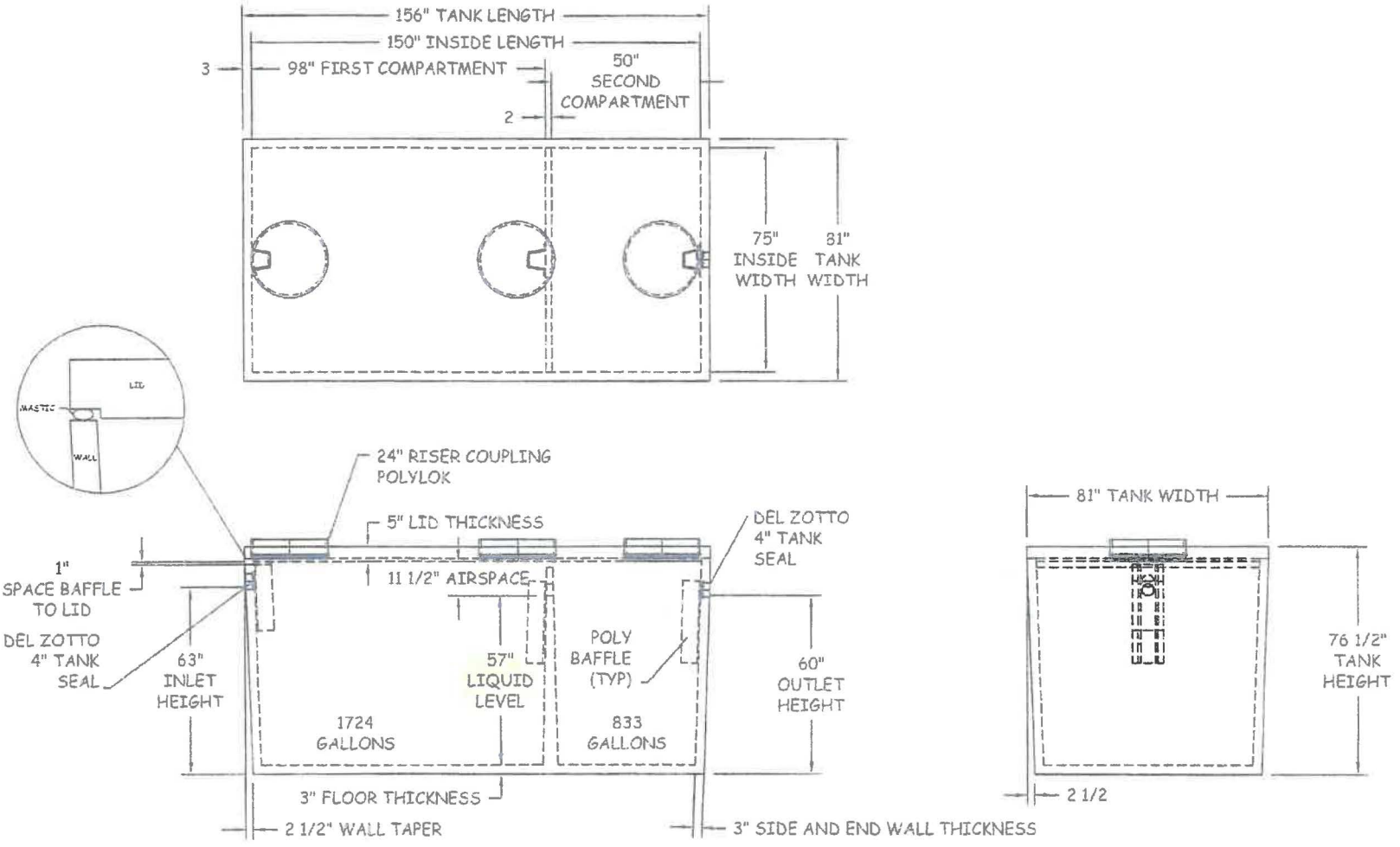

SHOWN AS A DZ-2500 C -S/S

This drawing and the information contained herein is the exclusive property of Del Zotto of Minnesota, Inc. and shall not be reproduced, used or disclosed to others except as authorized through written consent from Del Zotto of Minnesota, Inc.

UNLESS OTHERWISE SPECIFIED: DIMENSIONS ARE IN INCHES TOLERANCE ON DECIMALS: 0.03 FRACTIONS: 1/16 ANGLE: 1/2° REMOVE ALL BLURS AND BREAK ALL SHARP EDGES.

Del Zotto Products of Minnesota
 1900 County Road #1, Wrenshall, MN 55797 218-384-3068 Fax 218-384-3088

DRAWING DESCRIPTION: DZ-2500 C -S/S -S/P Septic Tank

SIZE: A	DRN BY: TAV	REV: D
File Name: Q2D22500CSSSPCADD	SCALE: 1:48	DATE: 12/04/2012
		SHEET: 1 OF 1

ATTACHMENT C