

New Mechanical Wastewater treatment facility with Extended Aeration and Activated Sludge with Filters.

Existing WWTP

- Is nearing Capacity
- Is not meeting the MPCS Effluent Phosphorus Limits and has received notices of violations
- Is approximately 25 years old and nearing the end of its design life
- Consists of two aeration basins, a final clarifier, a chlorine contact chamber, and a biosolids storage tank
- The permitted average wet weather flow of the existing facility is 0.353 MGD.

New Mechanical Wastewater Treatment Facility

- Utilizes pumps, blowers, and tanks to provide biological and chemical treatment of wastewater
- Provides a higher degree of treatment
- Consists of screening, biological treatment, solids separation, disinfection, and sludge treatment
- The new facility will meet the stringent phosphorus limit

The process flow diagram below shows the process for the new WWTF.

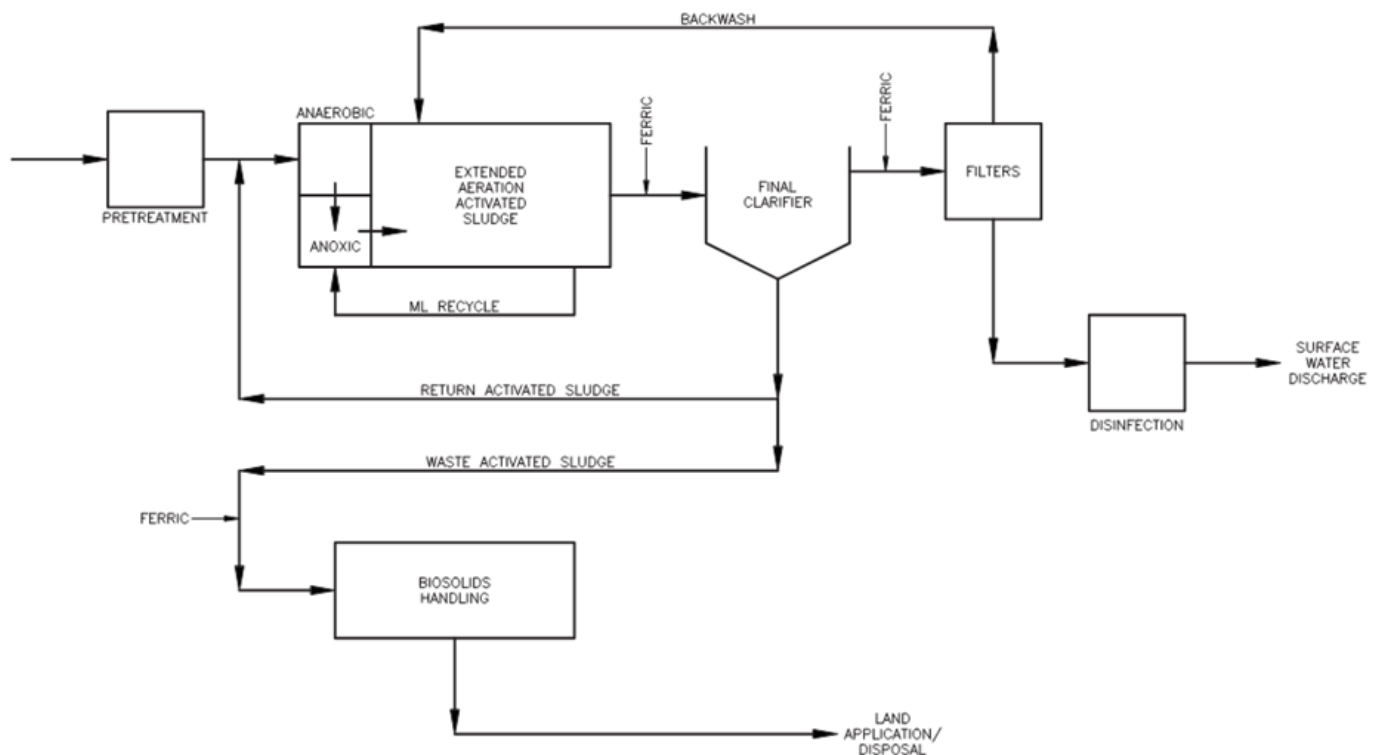

Summary of Improvements

Lift Station

The new Lift station will be constructed on the existing WWTF site to handle the Peak Hourly Wet Weather Flow.

Pretreatment Building

The new Pretreatment building will include a mechanical fine screen for the removal of large items and a vortex grit system to remove sand and grit. This will help protect the equipment in rest of the WWTF.

Aeration Basin

The new aeration basin will be constructed in a series for nitrification and phosphorus removal. The first basin is anaerobic which causes the release of phosphorus. The second basin is anoxic and allows for denitrification. The third basin consists of three aerobic basins which consume the organic matter, nitrify the ammonia, and uptake excess phosphorus.

Final Clarification

Reuse the existing final clarifier and construct a new 40-foot diameter final clarifier for an increase in treatment capacity and redundancy. Install covers for the final clarifiers to avoid the freezing of equipment during the winter months. The final clarifiers are designed to separate solids from the liquid stream. The solids will settle to the bottom and become Return Activated Sludge which is pumped back to the aeration basins while the liquid stream will go to the filters. Chemical is added in the final clarifiers to aid in the removal of phosphorus.

The activated sludge process will require new sludge handling pumps, piping, and valves.

Tertiary Treatment/Filters

The new sand filters will be used to remove fine solids from the waste stream, this will include the removal of phosphorus. The filters are needed to reach the stringent phosphorus limit.

Disinfection

Chlorine will continue to be used for this process. A new chlorine feed system will be installed to treat the increase in capacity.

Biosolids

The additional biosolids storage tank combined with the existing biosolids storage tank will provide 365 days of storage. The tanks will have submersible mixers for mixing and submersible pumps for removal of biosolids. Once or twice per year the biosolids will be pumped and disposed through land application.